

OWNERS MANUAL

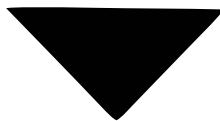

MODEL
SEWE300B

OWNERS MANUAL

MANUAL NO. 01

REV. DATE: 12/2022

DECWARE MODEL SEWE300B



ZEN TRIODE 300B

aka Sarah

OWNERS MANUAL

DESCRIPTION

The SEWE300B is a 4~7 watt per channel — single-ended triode amplifier using a single 300B output tube per channel driven by a pair of 6N6P/6922 driver tubes and a single 12AU7 input stage. Custom voicing can be accomplished by using different rectifiers and voltage regulation tubes of which there are three compatible values. The combination of these tubes determines the total power the amp will produce and the resulting sound signature. The amplifier is cathode biased so the 300B tubes are protected from accidental bias faults. It also sounds better to cathode bias, point to point wire, and many claim AC heaters sound better. This amp has all this and was built using our UFO output transformers. The amplifier has been built to the same 25th Anniversary standard as our SE84UFO25 with expensive parts including hardware and sockets.

DUAL VOLUME VS. SINGLE VOLUME CONTROLS

This amp comes with dual volume controls because it sounds better that way. It also eliminates the need for matched tubes between channels.

The main question one would have is why not simply have a volume control and a balance control? Reason: That puts two controls in the signal path instead of one. In an amplifier with only two resistors and one capacitor, adding additional parts, like these controls, in the signal path is audible. Remember, less is more and the goal is to preserve transparency - one of this amplifiers strongest traits.

Dual volume controls have another advantage besides half as many parts in the signal path when compared to a volume and balance control. With dual volume controls you can turn up one speaker by itself to a desired listening level and then turn up the other channel to match. Meaning you can make the second channel higher or lower without effecting the first channel. The advantage to doing this is that you can hear once you get close to a match between the channels the sound stage locks-in when you hit the right spot. Since your room is non-symmetrical and your speakers are in reality not matched to within 5% of each other, having the volume exactly perfectly centered between the channels is never the perfect spot. You'll hear it when you try it. And you'll notice a small window when you get close to matched where you can actually adjust the sound stage to your room a bit better.

OWNERS MANUAL

TUBES - output

The SEWE300B uses a single 300B output tube per channel. These are the larger ones on either side of the power transformer. The amplifier has been designed for and voiced around the Western Electric 300B tubes but has proven to be compatible with most brands and still sound very good.

We of course like the Western Electric 300B tubes because they are made in the USA and are the best quality and best sounding. Compared to the many we've tried they were among the most neutral and transparent.

Equally compelling but different sounding are the Cryotone 300B-WC tubes.

TUBES - input

The smaller 9 pin tubes in this amplifier are dual triodes configured as an SRPP stage to give maximum voltage swing with the least number of parts. These drive the output tubes, so there is one for each channel. We recommend 6N6P or 6922.

The single 9 pin tube in the front of the amplifier is a 12AU7. This is considered the input tube and is conventionally wired as a dual triode which is to say it effects both channels. This is the main tube for voicing of the amplifier. Different brand 12AU7 tubes will all sound slightly different. If you are going to explore tube rolling, this is the one to focus on.

TUBES - rectifier

The amplifier is designed for use with either 274B, 5U4 or 5AR4. Each of these tubes have a different voltage drop and will effect the sound and dynamics of the amplifier. The same can actually be said of different brands of each type of rectifier tube.

Rectifier tubes are the only thing that can blow the fuses in the amplifier so if your amp blows its fuses, it means your rectifier tube shorted or arced.

The amplifier draws 200mA of total current, so this means that **mesh plate 274B rectifier tubes will not work** because they are rated for less than that.

OWNERS MANUAL

BIASING and METERS

The SEWE300B is a self biasing, self balancing design meaning there is never a need to adjust the bias of the output tubes. The amp does it for you. The meters simply show the current draw of each of the two 300B tubes. Since this amplifier has dual volume controls it is not essential that the 300B tubes match. That said, it is nice to see the meters read similarly to +/- 10 milliamps.

The meters can also tell you at a glance if a tube has shorted or failed unexpectedly by suddenly reading abnormally high or low on one channel relative to the other channel.

SPEAKER BINDING POSTS - IMPEDANCE SWITCHES

The SEWE300B features heavy duty red copper binding posts for the speaker wires. They are the standard 5-way posts with standard spacing. They accept banana jacks, large spades, or bare wire up to 10 AWG in thickness. They are color coded with a RED and BLACK base. Black is the NEGATIVE speaker connection and RED is the positive speaker connection. There is a switch next to each pair of binding posts to set the speaker impedance between hi and lo. Please try both positions with music playing several times until you settle on the better sounding setting. Note: These switches are mirror imaged, so towards the power transformer is HI and switched pointing away from the transformer is LO.

BRIDGING INTO MONO

This amp can be run as a mono block (bridged) in two ways:

- A) Both the positive speaker jacks are connected together in parallel as are the negative jacks.
- B) The left negative jack is connected to the right positive jack (series) and the remaining to unused posts will then be used to drive the loudspeaker.

We recommend trying both ways. Way B usually sounds better and requires a short piece of wire to connect the two binding posts.

OWNERS MANUAL

INPUT JACKS

The selector switch for the input jacks is located directly between the jacks. The handle of the switch points to the active jack.

POWER UP

The power switch is located in the rear center of the amp. Since 300B tubes are directly heated you will see the meters rise to between 60 and 70 mA quickly. The exception to this would be when using a 5AR4 which soft starts the amp over 10 seconds or so.

VOICING SWITCHES

There are two voicing switches at the front of the amplifier next to each volume control. In the rear position the amplifier will have the deepest sound stage, while the front position will increase midrange presence moving the stage a little closer to the listener. These can be operated while you listen.

HUM BALANCE CONTROLS

There is knob above each meter that is used to adjust the hum balance for each channel. This is something you only have to adjust if you hear hum. When you hear hum you can adjust the knob in both directions until you find the center position where there is the least hum. The knob is touchy in that it takes very little movement to make the adjustments.

POWER CORD / FUSE

Your amplifier has a medical grade fused IEC connector with lighted power switch. Next to the switch is access to the fuses. There are two 5 amp fuses inside. Usually if one is blown, they are both blown. Size is 5x20mm. The amp will work with both fast and slow blow fuses.

OWNERS MANUAL

DECWARE UFO TRANSFORMERS

Since the output transformer is the only component you're hearing other than the two resistors and one capacitor inside the SEWE300B it should become obvious that this is a critical component relative to the overall fidelity of the amplifier. And given that, the quality of the power transformer and power supply in general is at the heart of the amplifiers performance.

Our transformers cores (shown left) are made with M-6 29 Gauge - 0.014" (0.355 mm) Grain Orientated Electrical Transformer Steel Lamination with steam blue oxide on the surfaces and edges to minimize stray losses between laminations.

This squared hysteresis loop iron-silicon alloy was expressly developed to provide lower core loss with higher permeability in the rolling direction. Grain oriented laminations are supplied in the stress relief annealed condition. The elementary patterns of the crystals in the material are "oriented", or arranged so that the axis of easiest magnetization is nearly parallel and aligned in the direction of rolling. The alignment is accomplished by a special cold-rolling and annealing processes. This allows the product to withstand more severe vibration and shock and enables the following:

1. Lower core losses as a consequence of design.
2. Higher initial permeability.
3. Higher permeability at higher inductions.
4. More stable VA / Temperature relationship over a wide range of ambient temperatures. The less the iron moves the more consistent the sound.

In 2015 we increased the interleaving and laminations to widen the bandwidth which resulted in flatter response in the audio band and even finer resolution.

Decware UFO output transformers are made in the USA.

OWNERS MANUAL

VOLTAGE REGULATOR TUBES and VOICING

The SEWE300B uses a total of 3 voltage regulator tubes. These are 7 pin tubes located near the front center of the amplifier.

The one on the left is for the left 6N6P driver tube. The one on the right is for the right 6N6P driver tube and the one in the middle is for the 12AU7 input tube.

These tubes are in series with the plates acting as esoteric power filters. They supply each tube with low noise DC current which is why the amplifier has no grain in the sound.

There are 3 types of voltage regulator (VR) tubes.

OC2 which has a voltage drop of 75 volts.

OB2 which has a voltage drop of 115 volts.

OA2 which has a voltage drop of 150 volts.

Since the voltage drop is different with each VR tube it means that you can use them to change the operating points of the audio tubes in the amplifier. That in turn dramatically alters the signature of the amplifier.

For example, let's just focus on the 12AU7 input tube and assume that you get curious about a different brand of 12AU7 that you would like to try because you heard people rave about it's sound. You need to know right away that in this amplifier the tube will sound three completely different ways depending on which VR tube is installed. If you have all three VR tubes on hand, it would essentially be like having 3 different 12AU7 tubes.

The same is true of the 6N6P/6922 driver tubes. Each of those has it's own VR tube.

As a general rule, the higher the voltage drop, the lushier the sound, while the lower the voltage drop, the cleaner the sound. Putting all OA2 in the amp would for example give it a more female presentation while putting all OC2 in the amp would give it a more male presentation.

OWNERS MANUAL

Below is an example of the possible VR tube combinations that can be used:

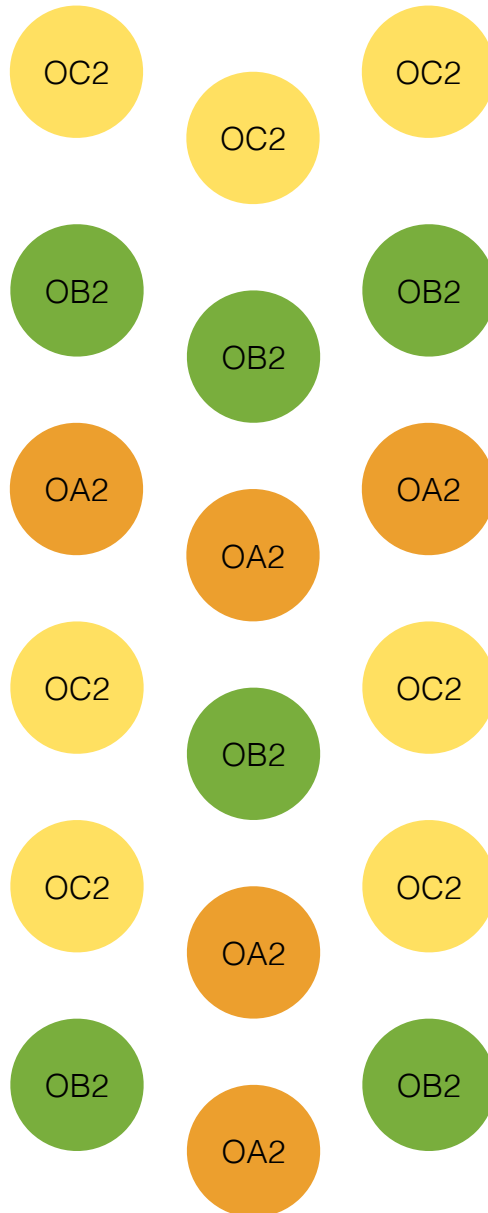

OWNERS MANUAL

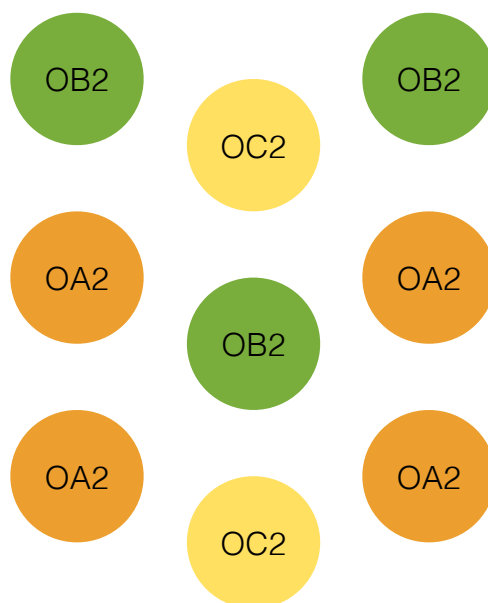

This basically means that the 3 audio tubes in your amplifier, a pair of 6N6P and one 12AU7, can make the amplifier sound 9 different ways.

Also these VR tubes effect the total power output of the amplifier. Using all OA2 for example would generate the least amount of power, around 4 or 5 watts while using all OC2 would create the most at around 6 or 7 watts. This is because we are rating the power with the dominant even order harmonic at 3% which is to say we stop turning the amp up when it reaches 3%. The voltage on the audio tubes determines this distortion content which in turn determines how loud we can turn it up.

HEADPHONES

There is no headphone jack offered on this amplifier because it is an AC heated triode so there would be some hum. We could have used DC heaters and gotten the amp quieter for headphone use, however we felt the AC sounded better.

OWNERS MANUAL

GROUND LOOPS, POWER STRIPS, HUM

Whenever we connect more than one audio component together we run the risk of creating a ground-loop which causes hum. Before you build a case for that first turn the volume all the way down on the amplifier and make sure you didn't accidentally turn one or both of the hum balance pots.

A ground loop happens when the path to ground in one component finds an easier (less resistive) path through another component via the ground or shield wire in your interconnects. This is a common problem when components are plugged into different outlets on a power strip as the resistance varies at the ground point of each receptacle.

To combat ground loops the amplifier has an isolated audio ground that is lifted above chassis/earth ground by 10 ohms.

To combat the noise from power strips and everything else the amp features a medical grade power filter.

We recommend plugging this amp directly into a hospital grade wall outlet or a heavy duty isolation transformer plugged into a hospital grade wall outlet.

Try to avoid power strips, noise filters/ 'main stream power conditioners', extension cords and cheap power cords to maintain a consistent sound quality.

MAINTENANCE

Tube life in this amplifier is 6,000 to 10,000 hours for all the small tubes. Best way to find out if one needs replaced is to replace it and see if the sound of the amp improves.

The 300B tubes from Western Electric have their own owner's manual linked next to this one on the Decware web site. Please read it. They are guaranteed for 5 years. Don't expect less expensive tubes from other countries to last as long.

The chassis can be cleaned with a light spray of Windex or similar window cleaner and a clean towel. Dusting is best done with a soft paint brush. The hardwood base can be maintained with furniture polish.

OWNERS MANUAL

BREAK-IN aka BURN-IN

When your amplifier is new, it will not sound as good as it does when it's several months old. The reason for this is the internal parts breaking in. The process typically involves the amp sounding a little harsh, or a little muddy, or having premature distortions when run at higher volumes. It can change from one to the other in as little as 15 minutes time. This process usually can occur during the first 100 hours of use. After the initial burn-in process, the amp will continue to season and refine over several months.

SOUND QUALITY

The fidelity of the amplifier, its frequency balance, pace, transparency, imaging and sound stage are extraordinary due to the small number of parts to get in the way of the music. That said, you will only ever hear it sound as good as the weakest link in your system, which could be cables, a preamp, your source component. The only way to hear how good the amplifier could sound would be to hook an analogue master tape machine with a live two track master tape where the recording was done with top notch microphones and engineering.

SOUND STAGE

Decware amplifiers are a benchmark for holographic sound where the music is completely 3D. In fact many people who watched movies using a two channel Decware amplifier thought there were 5 speakers playing. That said, give yourself a chance to experience it by occasionally pulling your speakers out into the room, several feet away from the walls. Toe them in to create an X just in front of your face and sit anywhere from 5 to 8 feet back. Close your eyes and we'll see ya when you return to Earth.

OWNERS MANUAL

USING SUBWOOFERS

Some powered subwoofers like REL brands require that the negative speaker jacks of each channel are tied together. To make this work with the SEWE300B, you can connect a wire between the two negative speaker binding posts at the back of the amplifier. This will mean that you can not bridge the amplifier into mono.

BRIDGING INTO MONO

The SEWE300B amplifier can be bridged into mono. Like all Decware Zen Triode amplifiers, it features a floating output stage where the negative speaker wires are not connected to ground. This allows the user to either parallel the outputs or wire them in series.

We recommend wiring the outputs in series by connecting the left channel positive binding post to the right channel negative binding post using a short piece of wire. The remaining two unused binding posts would be connected to the speaker.

The input jacks for both channels must see a signal for either parallel or series bridging. This is typically accomplished with an RCA Y-Cable.

Advantage of series bridging over parallel bridging is that in series the minute differences between channels (parts tolerance and tube drift) do not smear the sound. This is because both output tubes are in series which creates one large output tube. When bridged in series it is even possible to use two different brand 300B output tubes to create you own custom signature.

OWNERS MANUAL

DIFFERENTIAL BALANCED

It is actually possible when series bridging this amplifier to use a custom made cable set on the input jacks and change how you wire the output jacks that will turn the amplifiers into a fully differential balanced mono blocks. The custom cable would have XLR female on one end and two RCA male on the other. Below is a diagram of how to wire the amps.

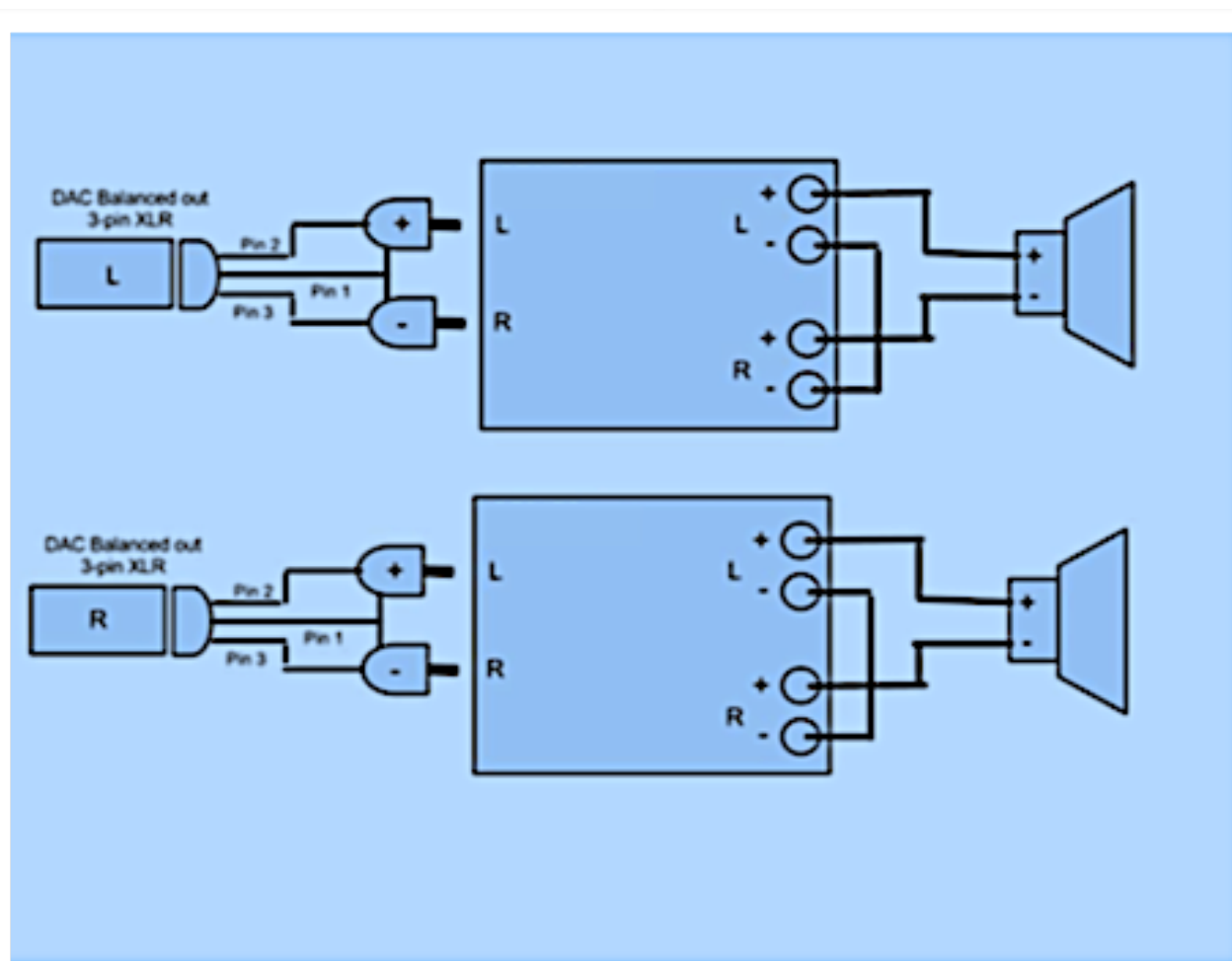

OWNERS MANUAL

WARRANTY

Your amplifier comes with a lifetime warranty to the original buyer. It covers defects in parts or labor. If you sell your amp for some reason, the buyer can return the amplifier to us for inspection and any updates at which point we can offer to transfer the lifetime warranty to him or her for a reasonable fee.

If your amp needs to return to the mothership, please call us first or at least e-mail with a description of the problem. Statistically 50% of all amps sent here for repair have nothing wrong with them. We can often head this off at the pass by consulting you over the phone and helping you to troubleshoot the problem. Decware amps are built to outlast you.

Returns should be sent to our main office. Please use the Return Form on our web site for the correct address and required information.

FINAL NOTE

We want this to be the best sounding amplifier you've owned and since these amps are like our children we have a vested interest in their continued success. Please call us any time you have questions or need advice on how to improve your sound, or room acoustics. We want you to love this thing as much as we do, and will bend over backwards to make sure you do.

-Steve Deckert / DECWARE